



VX0

Enter the world of vapor smoothing

Compact design

Small footprint all-in-one unit.
Maximising space efficiency.

Smooth operation

Streamlined controls and intuitive to operate.
It's not just user-friendly; it's effortlessly intuitive.

Plug & play

No complex setups or technical know-how required.
Enjoy a hassle-free experience from day one.

Sustainable cartridge system

Reusable cartridge system designed to minimize waste
and cut costs.

Material diversity

Ready for powder bed based PA12 materials.
PA11, TPU and PP will be added via software update.

Green and safe

Eco-friendly, FDA approved food-grade treatment agent.
For real peace of mind.

Technical Specifications

VX1 - Vapor Smoothing Machine

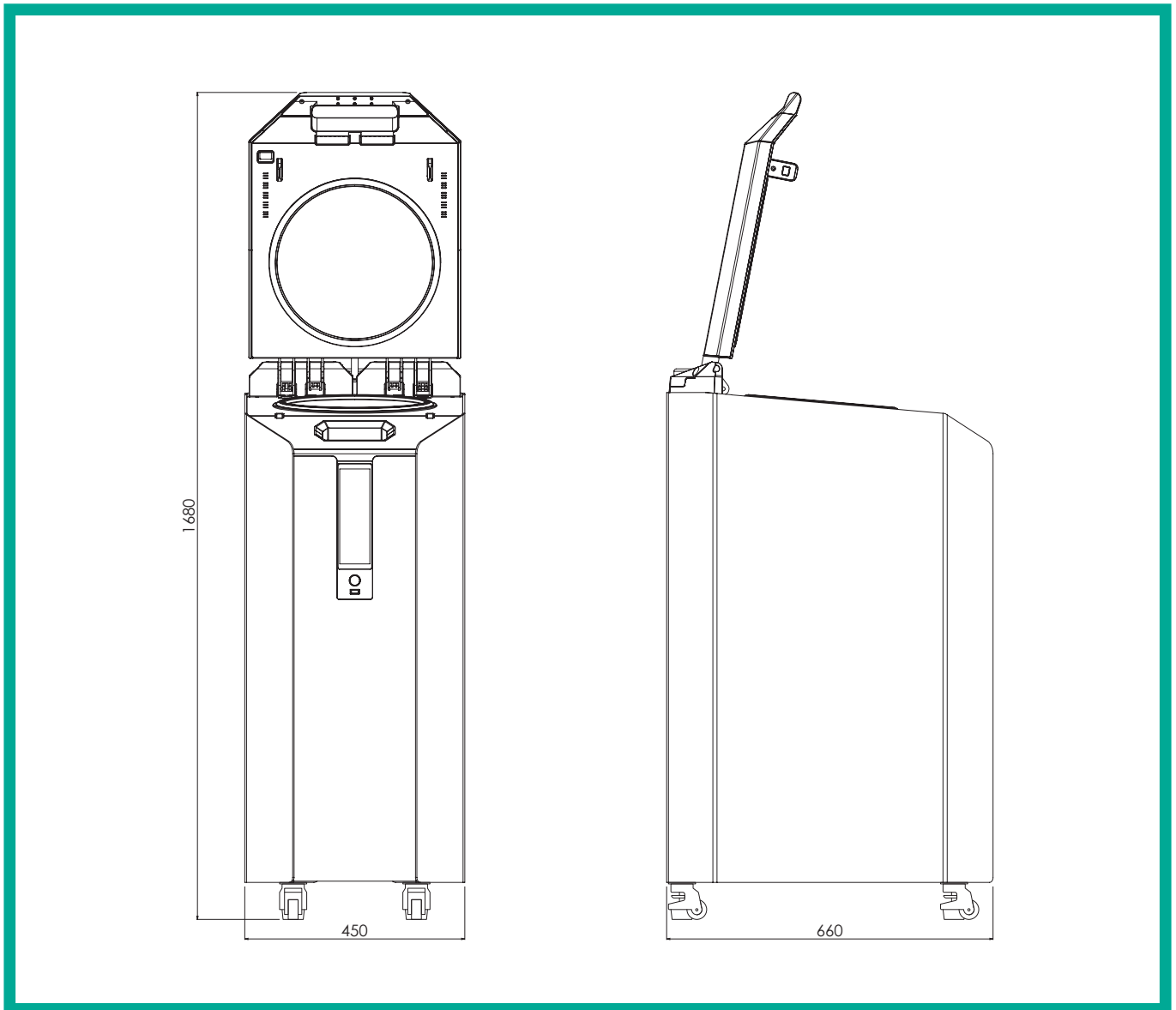

TECHNICAL DATA

Dimensions (W x D x H)	closed lid	450 × 660 × 1100 mm
	open lid	450 × 660 × 1680 mm
Process chamber volume (ø x H)		280 × 400 mm (24.6 L)
Recommended process volume (W x D x H)		180 × 220 × 340 mm (13.5 L)
Cycle time		1.5 to 2 h
Power requirements		230 V AC, 12 A (dedicated circuit)
Energy consumption		less than 1 kWh per cycle
Compatible materials		PA12 (PA11, TPU and PP in development)
Compatible printing processes		MJF, SLS, HSS, SAF
Treatment agent classification		pharmaceutical/food grade